

ENCOMS

Innovative solution for real-time, optimal control of water supply and distribution systems

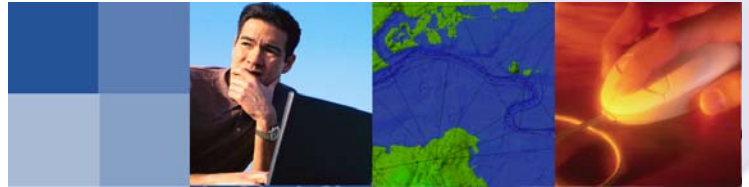

ENCOMS is an adaptive optimisation process for real-time, operational control of water distribution networks. ENCOMS, Initially developed by an EU consortium as part of the EC Framework V project POWADIMA and subsequently further developed by Halcrow, is designed to assist water distribution system operators in selecting cost-effective pump and valve settings to reduce operating costs and to provide more reliable and safer operations.

Resulting from groundbreaking advances in combined use of genetic algorithms and artificial neural networks, ENCOMS quickly identifies in real-time the optimal operational control settings that will best meet not only the current demands but also the projected ones along the operating horizon (usually 24 hours) at maximum cost savings, taking account of the electricity tariff structure and other system operational constraints aimed at ensuring safe, reliable operations. The real-time control process operates continually and is updated at a short interval by SCADA data and new demand forecast. Furthermore, this process has also been extended to include an emergency procedure dealing with unforeseen events, such as pump failures, pipe bursts, etc.

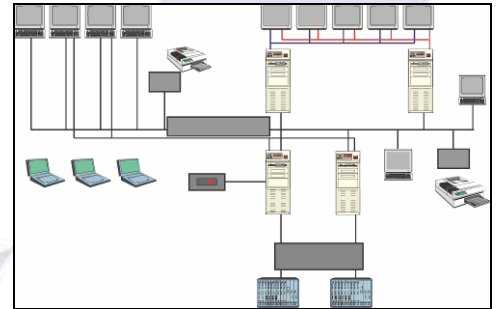

Main Modules

- On-line data collection
- Real-time demand forecasting
- Real-time model calibration
- Real-time pumping schedules and valve settings
- Short and long-term maintenance scheduling

Key Features

- Optimizes pumping schedules and valve settings in real time
- Maximizes use of lowest cost water source within any constraints
- Maximizes use of off-peak electricity periods within any constraints
- Forward predicts daily pattern of water consumption online
- Handles multiple sources of water and unlimited storage or demand points
- Allows manual scheduling of maintenance for plants and pumps
- Designs real-time response strategy for emergency scenarios

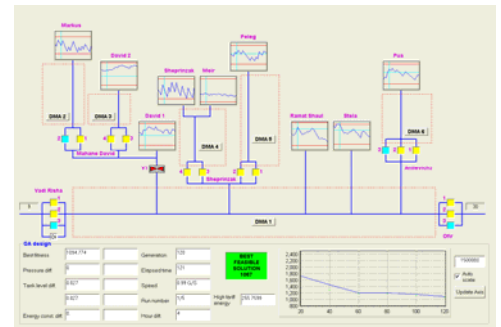

How much money and energy could you save if you could fine-tune every aspect of your pump and valve operations for maximum efficiency?

Two case studies undertaken by using ENCOMS indicated that the potential savings in power and energy costs by fine-tuning the pump and valve operations are significant and likely to be in the order of 20 percent.

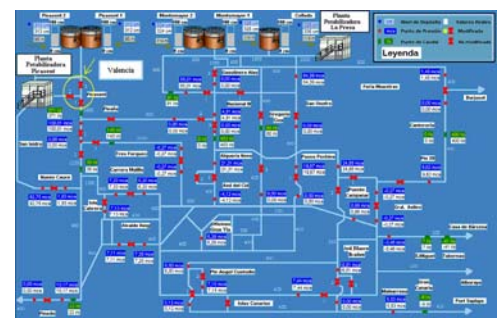

Key Benefits

- Assisting the water industry to reduce power costs and leakage from the distribution networks
- Seeking lowest cost, reliable solution for water supply and distribution system operations
- Improving the standards of service provided to customers in terms of supply pressures, water quality and continuity of supply
- Enabling capital investment in the infrastructure to meet genuine demand to be deferred by reducing losses from the water distribution network



For further information about ENCOMS please contact:
Zhengfu Rao (raoz@halcrow.com) or Jon Wicks (wicksjm@halcrow.com)

Innovative software solutions for smarter working

Halcrow